

STE 16/18/20

48-Volt Electric 3 wheel Lift Trucks

1600 kg

1800 kg

2000 kg

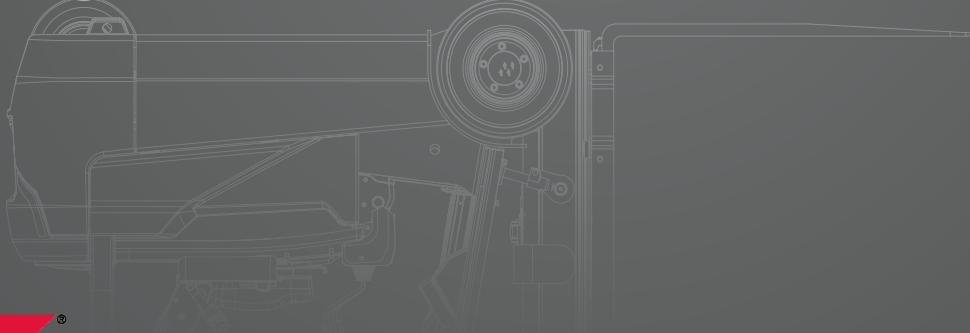
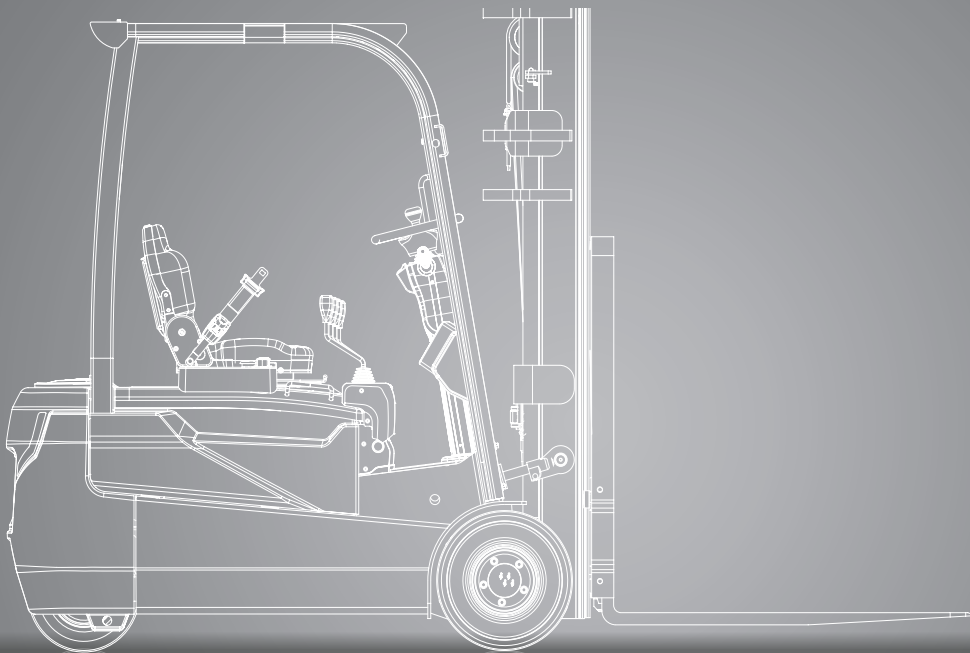

DIMENSIONS

STE16/18/20

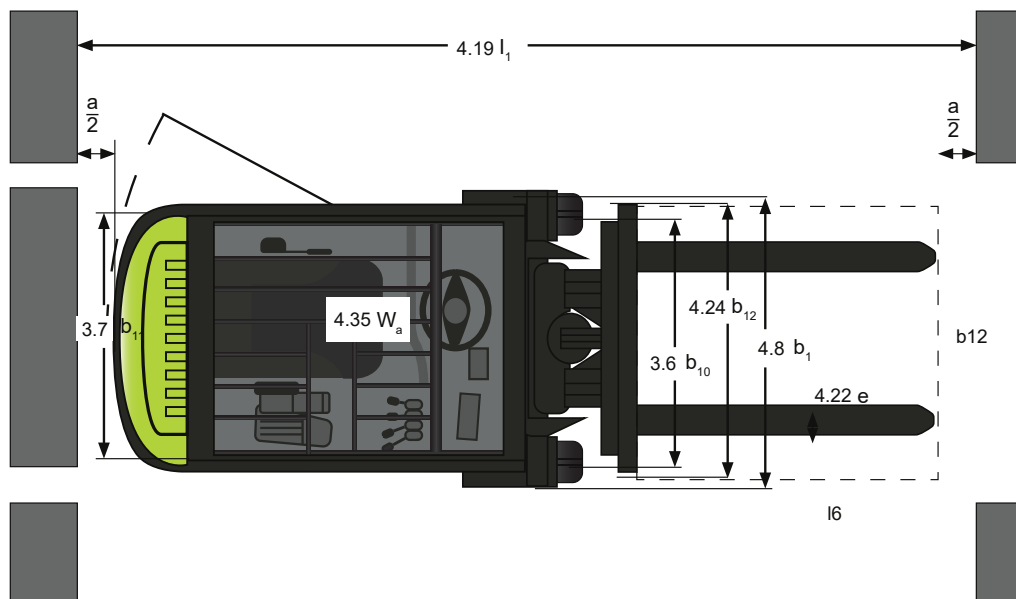
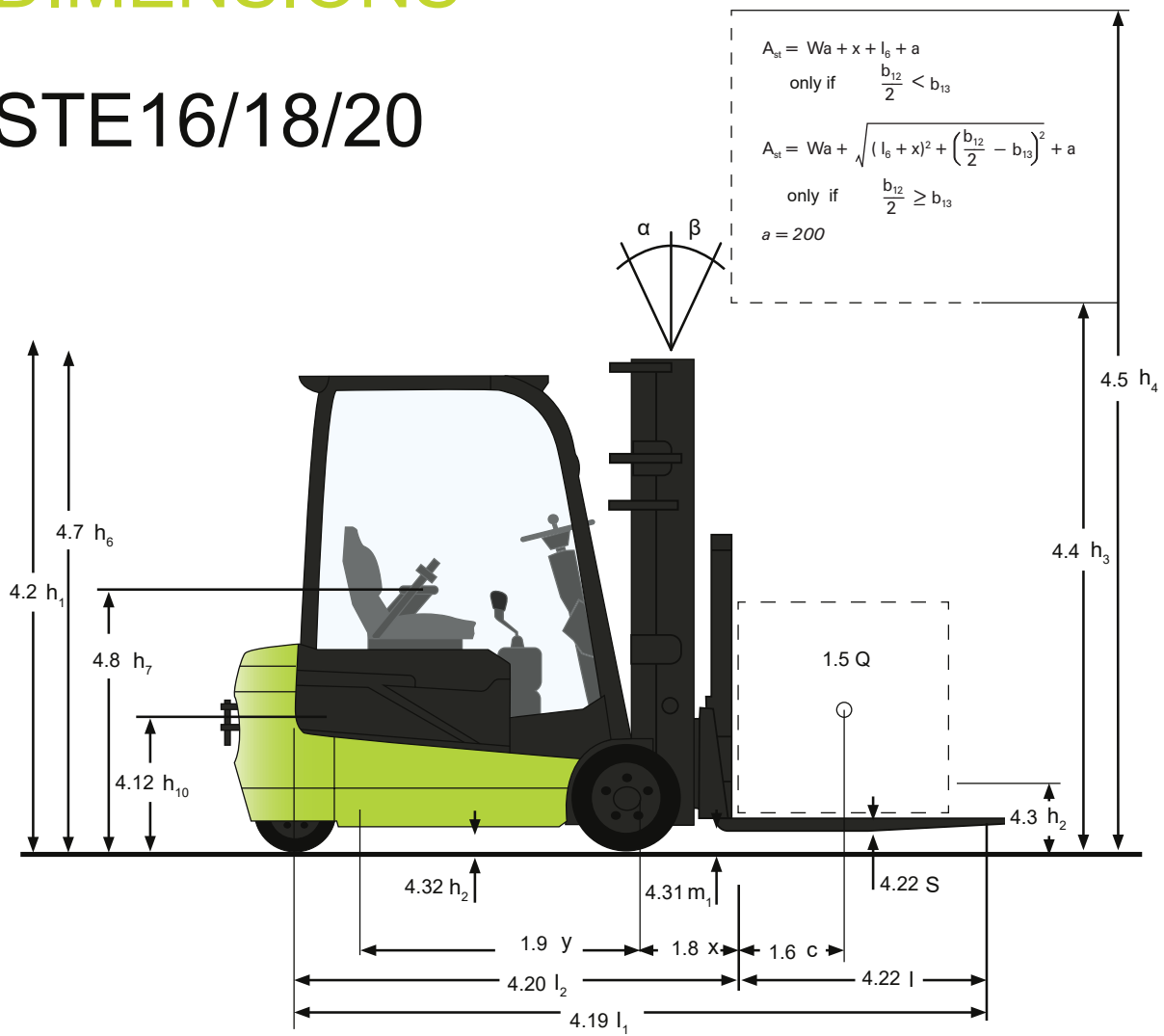

For corresponding data see specification chart.

SPECIFICATIONS acc. to VDI 2198

	1.1	Manufacturer (Abbreviation)	CLARK	CLARK	CLARK		
Specifications	1.2	Manufacturer's designation	STE16	STE18	STE20		
	1.3	Drive unit	Electric-48V	Electric-48V	Electric-48V		
	1.4	Operator type stand on/driver seated	Driver-seated	Driver-seated	Driver-seated		
	1.5	Load capacity/rated load	Q (kg)	1600	1800	2000	
	1.6	Load centre distance	c (mm)	500	500	500	
	1.8	Load centre distance, centre of drive axle to fork face	x (mm)	361	361	361	
	1.9	Wheelbase	y (mm)	1312	1420	1420	
Weight	2.1	Service weight	kg	3071	3202	3395	
	2.2	Axle loading, laden front/rear	kg	4188 / 483	4462 / 541	4809 / 586	
	2.3	Axle loading, unladen front/rear	kg	1621 / 1450	1575 / 1627	1602 / 1793	
Tyres, Chassis	3.1	Tyre type, SE = superelastic, C = cushion	Superelastic (SE)	Superelastic (SE)	Superelastic (SE)		
	3.2	Tyre size, front, superelastic	18 x 7-8	18 x 7-8	200 / 50-10		
	3.3	Tyre size, rear, superelastic	15 x 4,5 x 8	15 x 4,5 x 8	15 x 4,5 x 8		
	3.5	Wheels, number front/rear (x = drive wheels)	2 x / 2	2 x / 2	2 x / 2		
	3.6	Tread, front	b ₁₀ (mm)	905	905	915	
	3.7	Tread, rear	b ₁₁ (mm)	194	194	194	
	Dimensions	4.1	Tilt of upright/fork carriage, α / β	deg	6/6	6/6	6/6
4.2		Height, upright lowered	h ₁ (mm)	2052	2052	2052	
4.3		Freelift	h ₂ (mm)	132	132	132	
4.4		Lift height *1	h ₃ (mm)	3085	3085	3085	
4.5		Height, upright extended	h ₄ (mm)	3704	3704	3709	
4.7		Height overheadguard (Cabin)	h ₆ (mm)	2066 (2101)	2066 (2101)	2066 (2101)	
4.8		Seat height	h ₇ (mm)	1020	1020	1020	
4.12		Coupling height	h ₁₀ (mm)	360	360	360	
4.19		Overall length	l ₁ (mm)	2976	3084	3129	
4.20		Length to face of forks	l ₂ (mm)	1906	2014	2059	
4.21		Width	b ₁ (mm)	1059	1059	1122	
4.22		Fork dimensions	s*e*1 (mm)	40 x 100 x 1070	40 x 100 x 1070	40 x 100 x 1070	
4.23		Fork carriage DIN 15173, class / form A, B		II A	II A	II A	
4.24		Fork carriage width	b ₃ (mm)	940	940	940	
Performance		5.1	Travel speed laden/unladen	Km/h	15 / 15	15 / 15	15 / 15
	5.2	Lift speed laden/unladen	m/s	0,40 / 0,50	0,37 / 0,50	0,28 / 0,49	
	5.3	Lowering speed laden/unladen	m/s	0,57 / 0,52	0,57 / 0,52	0,57 / 0,52	
	5.6	max. drawbar pull laden/unladen (S2 5 min.) *2	N	16520 / 7564	16432 / 7387	16108 / 7495	
	5.8	max. gradeability laden/unladen (S2 5 min.) *2	%	27,0 / 22,0	26,0 / 21,0	25,0 / 20,0	
	5.10	Service brake		wet-disc brake	wet-disc brake	wet-disc brake	
	Drive line	6.1	Drive motor rating (S2 60 Min.)	kW	2 x 4,4	2 x 4,4	2 x 4,4
		6.2	Lift motor rating S3 15 %	kW	15,2	15,2	15,2
6.3		Battery acc. to DIN43531/35/36 A,B,C, no		DIN43531A	DIN43531A	DIN43531A	
6.4		Battery voltage, nominal capacity K5	V/Ah	48 / 460 (500)	48 / 575 (625)	48 / 575 (625)	
6.4.1		Battery voltage, nominal capacity K5 Li-Ion	V/Ah	48 / 460	48 / 460	48 / 460	
6.5		Battery weight (min.)	kg	708	856	856	
Misc.	8.1	Type of control		AC / Inverter	AC / Inverter	AC / Inverter	
	8.2	Operating pressure for attachments	bar	max. 140	max. 140	max. 140	
	8.3	Sound level, driver's ear DIN/EN 12053	dB (A)	68	68	68	

*1 Further lift heights see upright table

*2 At friction coefficient $\mu=0.6$ with 1.6 km/h

All values shown are for standard lift truck with standard equipment. If the truck is supplied with options, values may change. The specifications apply under normal operating conditions. All values given may vary + 5 % and - 10 % due to the motor and system tolerances and represent nominal values obtained under typical operating conditions. CLARK reserves the right to change products and specifications without prior notice.

PRODUCT DESCRIPTION

The CLARK STE16-20 three-wheel forklift trucks offer performance, safety and ergonomics. The electric counterbalance trucks keep your logistics moving - without harmful emissions. With our advanced SMART display, which informs the operator of all important driving parameters, the two powerful, low-noise drive motors and a design that is built to last, the STE16/20 represents the next generation of electric forklift trucks.

Lithium-Ion-Technology

Thanks to fast charging times, the STE16-20 electric forklift trucks with lithium-ion battery (Li-Ion) can be used almost without interruption. Take advantage of the optional fully integrated Li-ion battery. The CLARK lithium-ion battery with 48 volts and either 280 or 460 Ah can be used for both wheelbases (battery compartments). The charger with 48 volts, 160 A requires a power connection (CEE 16A plug). The battery management system (BMS) has a safety cut-out and thus ensures safe use of the battery. Possible error codes of the BMS are shown on the vehicle display.

Operator compartment

- Ergonomic operator compartment with plenty of legroom
- Minimum vibrations
- Non-slip metal step (step height: 410 mm)
- Non-slip foot area
- Large grab handle on the driver's side makes it easier to get on and off the vehicle
- Adjustable steering column for more leg and foot room
- Small steering wheel diameter ($\varnothing = 300$ mm)
- Adjustable seats with mechanical or air suspension
- Hydraulic control via lever on the hood or electronic hydraulic control via mini lever
- Ergonomically arranged drive and brake pedals
- Low front panelling for the best view
- Very good mast view
- Storage box and document holder with optional USB charging port

Smart-Display

- Clear, easy-to-read 5-inch colour display
- Splash-proof (IP65)
- Maintenance display and password-protected service access
- Customisable driving behaviour (including adjustable acceleration, electric braking behaviour and speed reduction when cornering)

DRIVE AND CONTROL SYSTEM

Drive motors

- Two powerful AC motors, each with 4.4 kW and 48 V three-phase technology
- Automatic protection: The motor power is automatically reduced to protect components from overheating.
- ZAPI DUAL AC control unit is protected in the counterweight

Steering system

- Hydraulic power steering
- Robust steering axle
- Automatically engaging electric parking brake with roll-back protection on inclines and ramps
- Maintenance-free wet disc brake

Hydraulics

- Large hydraulic oil tank ensures that there is always enough hydraulic oil for all mast and attachment types
- Full-flow return filter filters the oil every time it returns to the tank; coarse particles are filtered directly via a suction filter and therefore do not enter the oil circuit. This ensures a long service life for all hydraulic components.

Upright

- The free-view masts are available in Standard, Hilo and Triplex versions
- Excellent visibility
- CLARK mast damping absorbs vibrations during the transition between the individual mast stages
- Robust 6-roller fork carriage with adjustable side support rollers for long durability

Additional standard equipment

- Front headlights (LED)
- SE-tyres
- Indicator, rear combination lamp with brake light and white rear light (LED)
- Painted in bright safety colour „CLARK HOT YELLOW GREEN“
- Overhead guard and mast in matt black, wheel rims in white

Safety

The STE series is CE-certified and complies with all European safety standards. Contact your local CLARK dealer to find the right configuration for your needs.

GENERAL DATA

Truck Capacities at different load centres

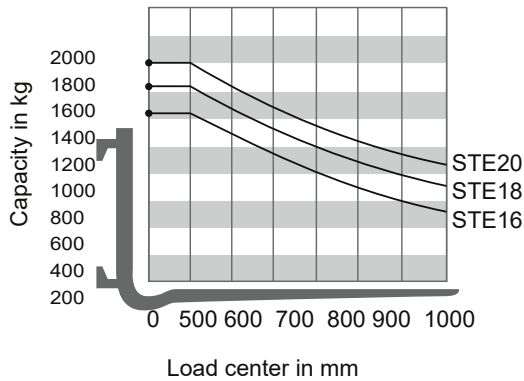

Note:

The listed capacities are valid only for the standard upright in vertical position with standard fork carriage and standard forks, up to max. lifting height of 3085 mm. The centre of gravity of the load may be displaced by max. 100 mm against the longitudinal centre plane of the truck. Load centre is determined from top and front face of the forks. The values are based on a 1000 mm cube load configuration with the centre of gravity at the true centre of the cube with upright tilted forward lower capacity values are valid. Attachments, longer forks, exceptional load dimensions and higher lifting heights can reduce the capacity.

Please talk to your CLARK dealer if you require further information.

Upright table STE16/18/20

Mast type	Lift height (h3) mm	Mast height lowered (h1) mm	Mast height extended (h4)		Free lift (h2)	
			with load backrest mm	without load backrest mm	with load backrest mm	without load backrest mm
Standard	2545	1792	3771	3169	132	132
	2795	1917	4021	3419		
	3085	2062	4311	3709		
	3285	2162	4511	3909		
	3639	2339	4865	4263		
	4069	2612	5295	4693		
	4365	2812	5591	4989		
	4653	3007	5879	5277		
Triplex	3970	1835	5194	4594	611	1211
	4345	1960	5569	4969	736	1336
	4780	2105	6004	5404	881	1481
	5185	2255	6409	5809	1031	1631
	5565	2415	6789	6189	1191	1791
	5740	2480	6964	6364	1256	1856
	6015	2605	7239	6639	1381	1981
	6470	2795	7694	7094	1571	2171
	7075	3050	8299	7699	1826	2426
HI-LO	2925	1960	4149	3549	736	1336
	3215	2105	4439	3839	881	1481
	3515	2255	4739	4139	1031	1631
	3695	2345	4919	4319	1121	1721
	3810	2415	5034	4434	1191	1791

FEATURES & EQUIPMENT EXTRAS



	Equipment features	STE16/18/20
General	Two powerful, low-maintenance AC drive motors	•
	Ergonomic driver's seat with plenty of legroom	•
	Nested mast profiles with optimum visibility and mast damping	•
	Automatically engaging, electric parking brake	•
	Intuitive 5-inch SMART display	X
	Prepared for the use of either Li-ion batteries or lead-acid batteries	•
Operator compartment and Control panel	Weather protection, PVC or full cabin with heating	•
	Low access height of only 410 mm	X
	Step with anti-slip coating	•
	Overhead guard for drive-in racks	X
	Storage trays	•
	Storage tray with USB charging port	X
	Splash-proof display (IP65)	•
	Direction switch on the hydraulic lever	X
	Hydraulic control via mini-lever	X
	Direction switch on the mini-lever	X
	Load weight indicator	X
	Direction indicator on the display	•
	Radio/MP3 player with Bluetooth	•
Ergonomics	Power steering	•
	Adjustable driver's seat & backrest	•
	Various driver's seats with mechanical or air suspension	X

	Equipment features	STE16/18/20
Ergonomics	Seats with safety bars or armrests	X
	Rear grab with horn	X
	Steering wheel (adjustable)	•
	Panoramic rear-view mirror	X
Battery and charging	Version for lateral battery change via roller frame	X
	Battery changing tables with castor frame	X
	Different charging technologies	X
Performance and productivity	Fork positioner with sideshift	X
	Integrated and hook-on sideshift	X
	Adjustable performance parameters (three programmable driving profiles available)	X
	Li-ion batteries or lead-acid batteries can be replaced and retrofitted by the service technician	•
Safety	Blue LED warning lights (for both directions of travel)	X
	Seat belt control	•
	Seat belt control with sequence check	X
	Hydraulic accumulator mounted on mast	X
	Automatic reduction of travelling speed when cornering	•
	Automatic parking brake	•
	Vertical mast position (VMS-system)	X
	Rear-view camera	X
Maintenance	LED-lighting	•
	Speed limit (can be set via the service)	•
	Fault diagnosis with fault indication on the display	•

• Standard Equipment X Option

<p>CLARK Europe GmbH Dr.- Alfred-Herrhausen-Allee 33 D - 47228 Duisburg / Germany Tel. +49 (0)2065 499 13-0 Fax +49 (0)2065 499 13-290 email: info-europe@clarkmheu.com www.clarkmheu.com</p>	<p>Dealer:</p>
-------------------------------------------------------------------------------------------------------------------------------------------------------------------------------------------------------------------------------------------------------------------------------------------------------------------------------------------	----------------